

## KS2 Mathematics Expected Standard



# 10-4-10

'10 minutes a day for ten days'

## Answers

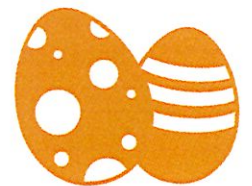

**Easter  
Revision  
2017**



**Arithmetic Questions**

1  $4 \times 5 \times 6 =$

$$4 \times 5 = 20$$

$$20 \times 6 = 120$$

$$(2 \times 6 = 12)$$

120

2  $283 \times 4 =$

$$\begin{array}{r} 283 \\ \times 4 \\ \hline 1132 \end{array}$$

1132



3  $45.76 + 15.951 =$

$$\begin{array}{r} 45.760 \\ + 15.951 \\ \hline 61.711 \end{array}$$

61.711

4  $5,967 - 2,395 =$

$$\begin{array}{r} 5\overset{8}{\cancel{9}}67 \\ - 2395 \\ \hline 3572 \end{array}$$

3572

5  $\frac{2}{5} + \frac{4}{5} =$

$$\frac{2}{5} + \frac{4}{5} = \frac{6}{5}$$

$$\frac{6}{5} = 1\frac{1}{5}$$

6/5 or 1 1/5

## DAY 1 – Reasoning Questions

1. The numbers in this sequence increase by the same amount each time. *Write the two missing numbers.*



2 marks

2. Circle the number that is closest to 400.



1 mark

3. A box contains 170 pens. 6 children each take 4 pens. How many pens are left in the box?

Show your method

2 marks

4. Write the missing numbers in the multiplication grid.

|   |    |    |     |
|---|----|----|-----|
|   | 9  | 4  | 70  |
| x |    |    |     |
| 5 | 45 | 20 | 350 |
| 6 | 54 | 24 | 420 |
| 3 | 27 | 12 | 210 |

2 marks

5. Here is a diagram for sorting numbers. Write **one number** in each box. One is done for you.

|                   | Square number     | Not a square number    |
|-------------------|-------------------|------------------------|
| Odd number        | 25                | 3,5,7,11,13,15,17...   |
| Not an odd number | 4, 16, 36, 64.... | 2, 6, 8, 10, 12, 14... |

2 marks

square = 1, 4, 9, 16, 25, 36, 49, 64, 81, 100

**Arithmetic Questions**

1  $560 \div 8 =$

$56 \div 8 = 7$

70

1 mark

2  $1/8 \times 14 =$

$\frac{1}{8} \times 14 = \frac{14}{8}$

$\frac{14}{8} = 1 \frac{6}{8}$

14/8 or 1 6/8

1 mark



3  $637.022 + 14.899 =$

$637.022$   
 $+ 14.899$   

---

 $651.921$

651.921

1 mark

4  $567 \div 3 =$

$189$   
 $3 \overline{)567}$

189

1 mark

5  $2.05 - 0.5 =$

$2.05$   
 $- 0.50$   

---

 $1.55$

1.55

1 mark

## DAY 2 – Reasoning Questions

1. Max jumped 2.25 metres on his second try at the long jump. This was 75 centimetres longer than on his first try. How far in metres did he jump on his first try? 1.5m or 150cm (1 mark)

$$\begin{array}{r} 2.25 \\ - 0.75 \\ \hline 1.50 \end{array}$$

2.

A packet contains 1.5 kilograms of guinea pig food. Remi feeds her guinea pig 30 grams of food each day.



How many days does the packet of food last?

Show your method

$$1.5 \text{ kg} = 1500 \text{ g}$$

$$1500 \div 30 = 50$$

**50**

(2 marks)

3. A bottle holds 1 litre of lemonade. Rachel fills 5 glasses with lemonade. She puts 150 millilitres in each glass. How much lemonade is left in the bottle?

$$5 \times 150 \text{ mL} = 750 \text{ mL} \quad \text{250 mL (1 mark)}$$

$$1 \text{ Litre} = 1000 \text{ mL} \quad 1000 - 750 = 250$$

4. One gram of silver costs £26.79.

What is the cost of  $\frac{1}{2}$  of a kilogram of silver?

Show your method

$$1 \text{ g} = \text{£}26.79$$

$$\frac{1}{2} \text{ kg} = 500 \text{ g}$$

$$\text{£}26.79 \times 500 = \text{£}13395$$

**£13395**

(2 marks)

5.

This fence has three posts, equally spaced.

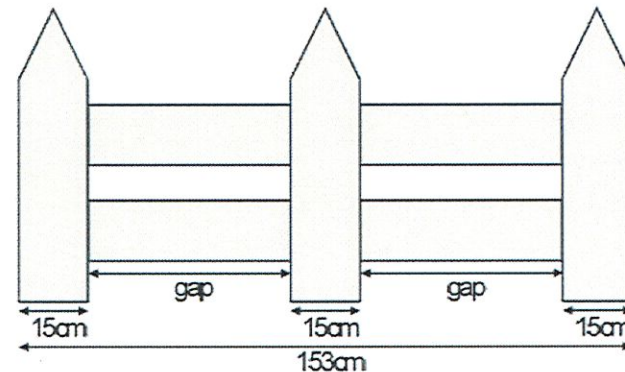

Each post is 15 centimetres wide.  
The length of the fence is 153 centimetres.  
Calculate the length of one gap between two posts.

$$153 \text{ cm} - 45 \text{ cm} = 108 \text{ cm}$$

$$108 \text{ cm} \div 2 = 54 \text{ cm each} \quad \text{54 cm (1 mark)}$$

# DAY 3

## Arithmetic Questions

1  $7,563 \div 26 =$

|     |    |    |   |   |   |   |   |                |  |  |  |  |  |
|-----|----|----|---|---|---|---|---|----------------|--|--|--|--|--|
|     |    |    |   |   |   |   |   |                |  |  |  |  |  |
| 26  | 1  |    |   |   | 2 | 9 | 0 | <sup>r23</sup> |  |  |  |  |  |
| 52  | 2  | 26 | 7 | 5 | 6 | 3 |   |                |  |  |  |  |  |
| 78  | 3  |    | 5 | 2 | ↓ |   |   |                |  |  |  |  |  |
| 104 | 4  |    | 2 | 3 | 6 |   |   |                |  |  |  |  |  |
| 130 | 5  |    | 2 | 3 | 4 | ↓ |   |                |  |  |  |  |  |
| 260 | 10 |    | 2 | 3 |   |   |   |                |  |  |  |  |  |
| 234 | 9  |    |   |   |   |   |   |                |  |  |  |  |  |
|     |    |    |   |   |   |   |   |                |  |  |  |  |  |
|     |    |    |   |   |   |   |   |                |  |  |  |  |  |
|     |    |    |   |   |   |   |   |                |  |  |  |  |  |
|     |    |    |   |   |   |   |   |                |  |  |  |  |  |
|     |    |    |   |   |   |   |   |                |  |  |  |  |  |
|     |    |    |   |   |   |   |   |                |  |  |  |  |  |
|     |    |    |   |   |   |   |   |                |  |  |  |  |  |
|     |    |    |   |   |   |   |   |                |  |  |  |  |  |
|     |    |    |   |   |   |   |   |                |  |  |  |  |  |
|     |    |    |   |   |   |   |   |                |  |  |  |  |  |

290<sup>r23</sup>    2

2  $2,067 + 8,589 =$

|  |  |   |   |   |   |   |  |  |  |  |  |  |  |
|--|--|---|---|---|---|---|--|--|--|--|--|--|--|
|  |  |   |   |   |   |   |  |  |  |  |  |  |  |
|  |  | 2 | 0 | 6 | 7 |   |  |  |  |  |  |  |  |
|  |  | + | 8 | 5 | 8 | 9 |  |  |  |  |  |  |  |
|  |  |   |   |   |   |   |  |  |  |  |  |  |  |
|  |  |   |   |   |   |   |  |  |  |  |  |  |  |
|  |  |   |   |   |   |   |  |  |  |  |  |  |  |
|  |  |   |   |   |   |   |  |  |  |  |  |  |  |
|  |  |   |   |   |   |   |  |  |  |  |  |  |  |
|  |  |   |   |   |   |   |  |  |  |  |  |  |  |
|  |  |   |   |   |   |   |  |  |  |  |  |  |  |
|  |  |   |   |   |   |   |  |  |  |  |  |  |  |
|  |  |   |   |   |   |   |  |  |  |  |  |  |  |
|  |  |   |   |   |   |   |  |  |  |  |  |  |  |
|  |  |   |   |   |   |   |  |  |  |  |  |  |  |
|  |  |   |   |   |   |   |  |  |  |  |  |  |  |
|  |  |   |   |   |   |   |  |  |  |  |  |  |  |
|  |  |   |   |   |   |   |  |  |  |  |  |  |  |
|  |  |   |   |   |   |   |  |  |  |  |  |  |  |
|  |  |   |   |   |   |   |  |  |  |  |  |  |  |

10656    1 mark



3  $100 \times 902 =$

|  |  |  |  |  |  |  |  |  |  |  |  |  |  |
|--|--|--|--|--|--|--|--|--|--|--|--|--|--|
|  |  |  |  |  |  |  |  |  |  |  |  |  |  |
|  |  |  |  |  |  |  |  |  |  |  |  |  |  |
|  |  |  |  |  |  |  |  |  |  |  |  |  |  |
|  |  |  |  |  |  |  |  |  |  |  |  |  |  |
|  |  |  |  |  |  |  |  |  |  |  |  |  |  |
|  |  |  |  |  |  |  |  |  |  |  |  |  |  |
|  |  |  |  |  |  |  |  |  |  |  |  |  |  |
|  |  |  |  |  |  |  |  |  |  |  |  |  |  |
|  |  |  |  |  |  |  |  |  |  |  |  |  |  |
|  |  |  |  |  |  |  |  |  |  |  |  |  |  |
|  |  |  |  |  |  |  |  |  |  |  |  |  |  |
|  |  |  |  |  |  |  |  |  |  |  |  |  |  |
|  |  |  |  |  |  |  |  |  |  |  |  |  |  |
|  |  |  |  |  |  |  |  |  |  |  |  |  |  |
|  |  |  |  |  |  |  |  |  |  |  |  |  |  |
|  |  |  |  |  |  |  |  |  |  |  |  |  |  |
|  |  |  |  |  |  |  |  |  |  |  |  |  |  |
|  |  |  |  |  |  |  |  |  |  |  |  |  |  |
|  |  |  |  |  |  |  |  |  |  |  |  |  |  |
|  |  |  |  |  |  |  |  |  |  |  |  |  |  |
|  |  |  |  |  |  |  |  |  |  |  |  |  |  |

90200    1 mark

4  $\frac{2}{3}$  of 90 =

$\frac{1}{3}$  of 90 = 30

$\frac{2}{3}$  of 90 = 30 x 2 = 60

|  |  |  |  |  |  |  |  |  |  |  |  |  |  |
|--|--|--|--|--|--|--|--|--|--|--|--|--|--|
|  |  |  |  |  |  |  |  |  |  |  |  |  |  |
|  |  |  |  |  |  |  |  |  |  |  |  |  |  |
|  |  |  |  |  |  |  |  |  |  |  |  |  |  |
|  |  |  |  |  |  |  |  |  |  |  |  |  |  |
|  |  |  |  |  |  |  |  |  |  |  |  |  |  |
|  |  |  |  |  |  |  |  |  |  |  |  |  |  |
|  |  |  |  |  |  |  |  |  |  |  |  |  |  |
|  |  |  |  |  |  |  |  |  |  |  |  |  |  |
|  |  |  |  |  |  |  |  |  |  |  |  |  |  |
|  |  |  |  |  |  |  |  |  |  |  |  |  |  |
|  |  |  |  |  |  |  |  |  |  |  |  |  |  |
|  |  |  |  |  |  |  |  |  |  |  |  |  |  |
|  |  |  |  |  |  |  |  |  |  |  |  |  |  |
|  |  |  |  |  |  |  |  |  |  |  |  |  |  |
|  |  |  |  |  |  |  |  |  |  |  |  |  |  |
|  |  |  |  |  |  |  |  |  |  |  |  |  |  |
|  |  |  |  |  |  |  |  |  |  |  |  |  |  |
|  |  |  |  |  |  |  |  |  |  |  |  |  |  |
|  |  |  |  |  |  |  |  |  |  |  |  |  |  |
|  |  |  |  |  |  |  |  |  |  |  |  |  |  |
|  |  |  |  |  |  |  |  |  |  |  |  |  |  |

60    1 mark

5  $4.5 \div 10 =$

|  |  |  |  |  |  |  |  |  |  |  |  |  |  |
|--|--|--|--|--|--|--|--|--|--|--|--|--|--|
|  |  |  |  |  |  |  |  |  |  |  |  |  |  |
|  |  |  |  |  |  |  |  |  |  |  |  |  |  |
|  |  |  |  |  |  |  |  |  |  |  |  |  |  |
|  |  |  |  |  |  |  |  |  |  |  |  |  |  |
|  |  |  |  |  |  |  |  |  |  |  |  |  |  |
|  |  |  |  |  |  |  |  |  |  |  |  |  |  |
|  |  |  |  |  |  |  |  |  |  |  |  |  |  |
|  |  |  |  |  |  |  |  |  |  |  |  |  |  |
|  |  |  |  |  |  |  |  |  |  |  |  |  |  |
|  |  |  |  |  |  |  |  |  |  |  |  |  |  |
|  |  |  |  |  |  |  |  |  |  |  |  |  |  |
|  |  |  |  |  |  |  |  |  |  |  |  |  |  |
|  |  |  |  |  |  |  |  |  |  |  |  |  |  |
|  |  |  |  |  |  |  |  |  |  |  |  |  |  |
|  |  |  |  |  |  |  |  |  |  |  |  |  |  |
|  |  |  |  |  |  |  |  |  |  |  |  |  |  |
|  |  |  |  |  |  |  |  |  |  |  |  |  |  |
|  |  |  |  |  |  |  |  |  |  |  |  |  |  |
|  |  |  |  |  |  |  |  |  |  |  |  |  |  |
|  |  |  |  |  |  |  |  |  |  |  |  |  |  |
|  |  |  |  |  |  |  |  |  |  |  |  |  |  |

0.45    1 mark

## DAY 3 – Reasoning Questions

1. Write the two missing values to make these equivalent fractions correct.

$$\boxed{6} = \frac{\quad}{3} = \frac{\quad}{9}$$

*Handwritten:  $\times 2$  from 3 to 6,  $\times 3$  from 3 to 9*

2.  $\frac{8}{4} = \frac{\quad}{12}$

*Handwritten:  $\div 2$  from 8 to 4,  $\times 3$  from 4 to 12*

(2 marks)

Shade  $\frac{1}{5}$  of this shape.

*Handwritten:  $\frac{1}{5}$  of 10 = 2*

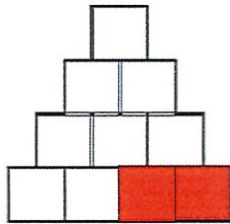

(1 mark)

3.  $480 \div \boxed{100} = 4.8$

(1 mark)

4.

Here is a pattern on a grid.

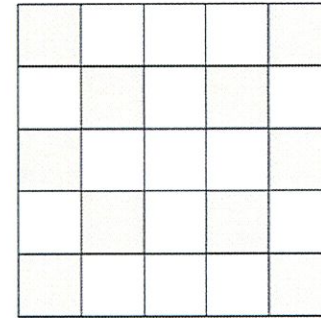

*Handwritten:  $\frac{10}{25} = \frac{40}{100}$  with arrows and  $\times 4$  indicating the simplification process.*

What percentage of the grid is shaded?

40% (1 mark)

5.

Match each decimal number to its equivalent fraction. One has been done for you.

0.25 ~~—~~  $\frac{3}{4}$   
 0.4 ~~—~~  $\frac{2}{10}$   
 0.75 ~~—~~  $\frac{1}{4}$   
 0.2 ~~—~~  $\frac{2}{5}$

*Handwritten:  $\frac{2}{5} = \frac{4}{10}$*

(1 mark)

6. Write in the missing numbers.

30% of 60 is 18      30% of 200 is 60

*Handwritten:*  
 $10\% \text{ of } 60 = 6$        $30\% = 60$   
 $6 \times 3 = 18$        $10\% = 20$   
 $20 \times 10 = 200$

(2 marks)



# DAY 4

## Arithmetic Questions

1  $3.45 \times \dots = 345$

100

2  $3 \times 7 = 4 \times 6 - \dots$

$3 \times 7 = 21$

$4 \times 6 = 24$

$24 - 3 = 21$

3



3  $438 \times 2 =$

$$\begin{array}{r} 438 \\ \times 2 \\ \hline 876 \\ \hline \end{array}$$

876

4  $\frac{3}{4} - \frac{2}{12} =$

$$\frac{3}{4} - \frac{2}{12} = \frac{9}{12} - \frac{2}{12} = \frac{7}{12}$$

7/12

5  $5,867 \div 4 =$

$$\begin{array}{r} 1466 \text{ r}3 \\ 4 \overline{) 5867} \\ \underline{4} \phantom{0} \phantom{0} \phantom{0} \\ 18 \phantom{0} \phantom{0} \phantom{0} \\ \underline{16} \phantom{0} \phantom{0} \phantom{0} \\ 26 \phantom{0} \phantom{0} \phantom{0} \\ \underline{20} \phantom{0} \phantom{0} \phantom{0} \\ 67 \phantom{0} \phantom{0} \\ \underline{64} \phantom{0} \phantom{0} \\ 27 \phantom{0} \\ \underline{24} \phantom{0} \\ 3 \phantom{0} \phantom{0} \phantom{0} \phantom{0} \end{array}$$

1466<sup>r3</sup>

## DAY 4 – Reasoning Questions

1.

Emily has 6 cubes.  
She sticks them together to make this model.

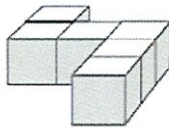

She paints the sides of the model grey all the way round. She leaves the top and the bottom of the model white.

How many of the cubes in the model have exactly two faces painted grey?

**4** (1 mark)

2.

Here are some shapes on a grid.

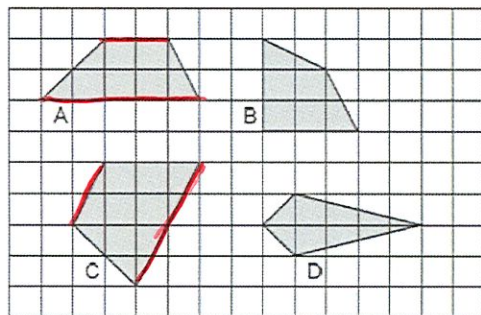

Write the letter of each shape that has one pair of parallel sides.

**A and C** (1 mark)

3.

Look at the triangle. Angle  $x$  is fifty-five degrees.  
Calculate the size of angle  $y$ .

$$90^\circ + 55^\circ = 145^\circ$$

$$180^\circ - 145^\circ = 35^\circ$$

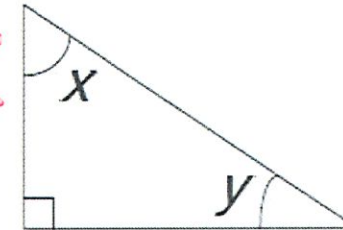

**35°** (1 mark)

4.

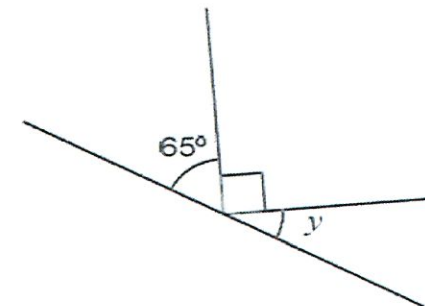

Not to scale

Calculate the size of angle  $y$  in this diagram.  
Do not use a protractor (angle measurer).

$$90^\circ + 65^\circ = 155^\circ$$

$$180^\circ - 155^\circ = 25^\circ$$

**25°** (1 mark)

**Arithmetic Questions**

1  =  $480 \div 60$

$48 \div 6 = 8$

1 mark

2  $-14 + 9 =$

$-14$        $-10$        $-5$

$+4$        $+5$

1 mark



3  $4 \frac{2}{3} - 1 \frac{1}{3} =$

$4 - 1 = 3$

$\frac{2}{3} - \frac{1}{3} = \frac{1}{3}$

1 mark

4 40% of £1,300 =

$10\% \text{ of } \pounds 1300 = \pounds 130$

$40\% \text{ of } \pounds 1300 = \pounds 130 \times 4$

$= \pounds 520$

1 mark

5  $79 - 2.95 =$

$79.00 - 2.95$

$76.05$

1 mark

## DAY 5 – Reasoning Questions

1.

In class 6T there are 3 girls to every 2 boys. There are 21 girls in the class. How many boys are there?

$$\begin{array}{l} G : B \\ 3 : 2 \\ \times 7 \quad \times 7 \\ \hline 21 : 14 \end{array}$$

14 (1 mark)

2.

A cupcake recipe uses 2 eggs for every 250g of flour. How many eggs are needed for 1kg of flour?

$$\begin{array}{l} e : f \\ 2 : 250g \\ \times 4 \quad \times 4 \\ \hline 8 : 1000g \end{array}$$

$$1\text{kg} = 1000\text{g}$$

8 (1 mark)

3.

Use the rule below to fill in the empty boxes.

Double a number and add 3

$$17 \longrightarrow \boxed{37}$$

$$\begin{array}{l} 17 + 17 = 34 \\ 34 + 3 = 37 \end{array}$$

$$\boxed{23} \longrightarrow 49$$

$$\begin{array}{l} 49 - 3 = 46 \\ 46 \div 2 = 23 \end{array}$$

(1 mark)

4.

Here is a sequence of patterns made from squares and circles.

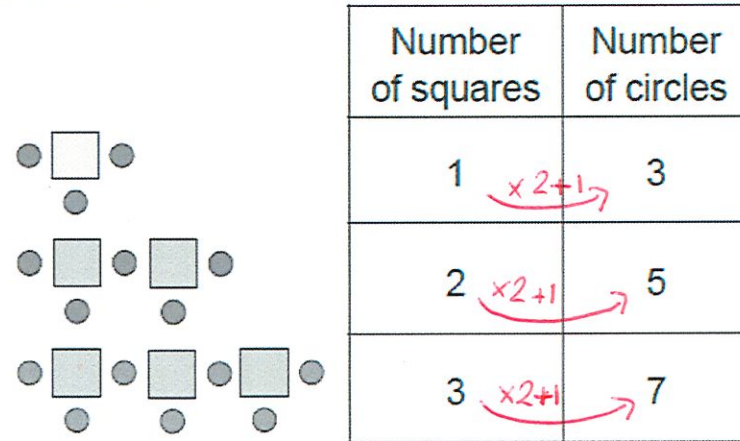

The sequence continues in the same way. Calculate how many squares there will be in the pattern which has 25 circles.

$$\begin{array}{l} 25 - 1 = 24 \\ 24 \div 2 = 12 \end{array}$$

12 (1 mark)

5.

$\square$  and  $\circ$  each stand for a different number.

$$\square = 34$$

$$\square + \square = \circ + \circ + \square$$

What is the value of  $\circ$ ?

$$\begin{array}{l} 34 + 34 = 68 \\ 68 - 34 = 34 \\ 34 \div 2 = 17 \end{array}$$

17 (1 mark)



# DAY 6 – Reasoning Questions

1 A school has a quiz each year. There are two teams. Here are their results.

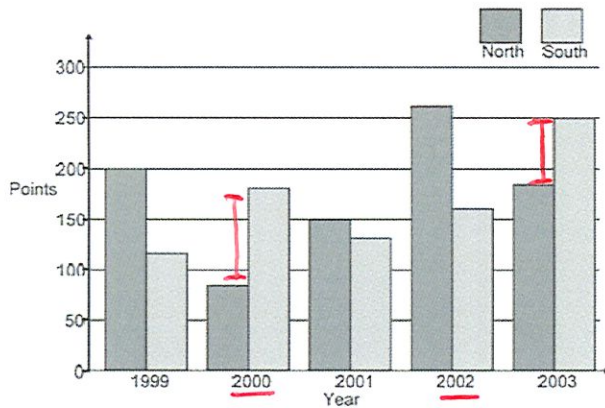

In which year did North beat South by 100 points? 2002 (1 mark)

In which year did South beat North by the greatest amount? 2000 (1 mark)

2. Brooklyn runs the 100m 5 times. These are his times in seconds.  $13 \cdot 2 + 14 \cdot 2 + 13 \cdot 5 + 14 \cdot 6 + 14 \cdot 5 = 70$   
 $70 \div 5 = 14$

|      |      |      |      |      |
|------|------|------|------|------|
| 13.2 | 14.2 | 13.5 | 14.6 | 14.5 |
|------|------|------|------|------|

What is his mean (average) time? 14 (1 mark)

3. The table shows the number of children attending rounders after school club. Fill in all the missing numbers in this table.

|       | Week 1 | Week 2 | Week 3 | Week 4 |
|-------|--------|--------|--------|--------|
| Boys  | 21     | 36     | 46     | 61     |
| Girls | 15     | 26     | 23     | 23     |
| Total | 36     | 62     | 69     | 84     |

$21 + 15 = 36$   $62 - 26 = 36$   $69 - 46 = 23$  (2 marks)  
 $84 - 23 = 61$

4

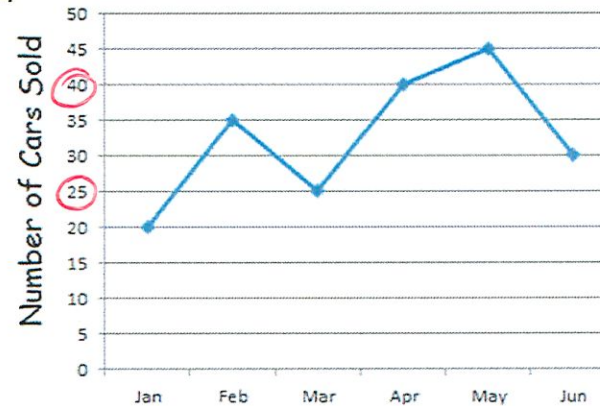

How many more cars were sold in April than in March? 15 (1 mark)

How many cars were sold in total between the beginning of January and the end of May? 165 (1 mark)

5. This pie chart looks at activities completed by 60 people on Saturday morning. What fraction of the people played?

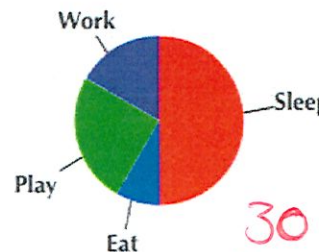

1/4 (1 mark)

What is the difference between the number of people that sleep and play?

$30 - 15 = 15$  (1 mark)  
 $1/4$  of 60 = 15

## Arithmetic Questions

1  $12,000 + 5,000 + \underline{\hspace{2cm}} = 18,300$

$$\begin{array}{r} 12000 \\ + 5000 \\ \hline 17000 \end{array}$$

$$18300 - 17000 =$$

1300

2  $45.6 + 10 =$

55.6



3  $674 \div 15 =$

$$\begin{array}{r} 44 \text{ r}14 \\ 15 \overline{) 674} \\ \underline{30} \phantom{2} \\ 45 \phantom{3} \\ \underline{60} \phantom{4} \\ 75 \phantom{5} \\ \underline{150} \phantom{10} \end{array}$$

44<sup>r14</sup>

4  $8^2 - 6^2 =$

$$8^2 = 8 \times 8 = 64$$

$$6^2 = 6 \times 6 = 36$$

$$64 - 36 = 28$$

28

5  $4 \times 7 \times 3 =$

$$4 \times 7 = 28$$

$$28 \times 3 = 84$$

$$\begin{array}{r} 28 \\ \times 3 \\ \hline 84 \\ \hline \end{array}$$

84

## DAY 7 – Reasoning Questions

1.

Find the perimeter of the shape below.

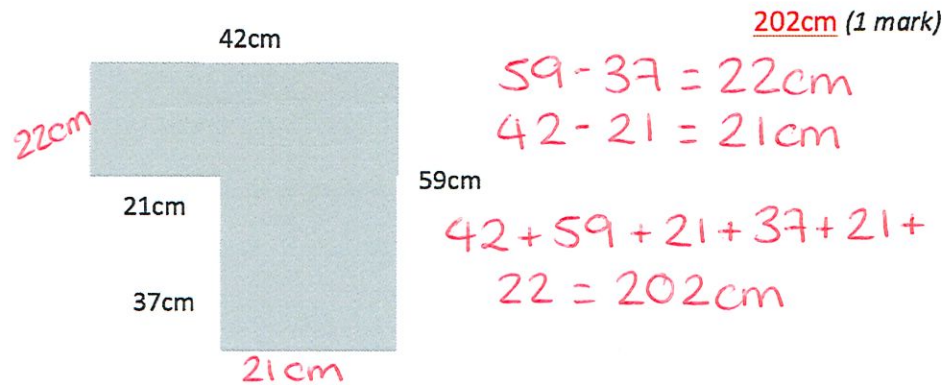

2.

A film starts at 6:45pm.

It lasts 2 hours and 35 minutes.

What time will the film finish?

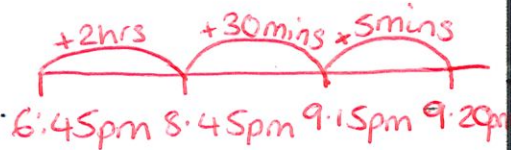

9:20pm (1 mark)

3.

Buses come once an hour at a twenty past the hour. Sophie arrives at the bus stop at 9:40am. How long should she have to wait for the next bus?

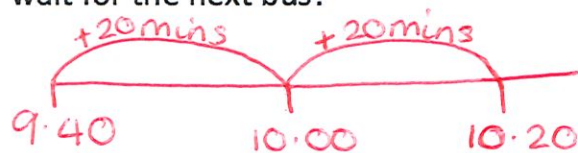

40 minutes (1 mark)

4.

What is the area of this shape?

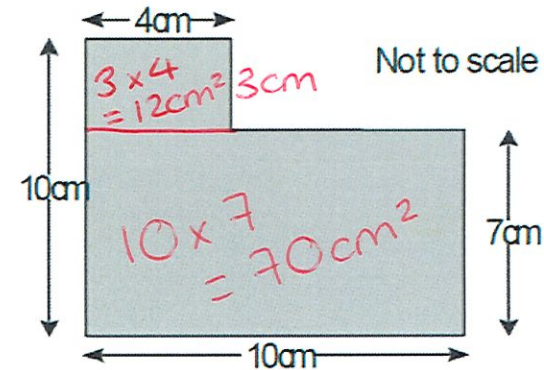

82cm<sup>2</sup> (1 mark)

5.

A square has four sides. One of its sides measures 67mm. Work out its area and perimeter in cm.

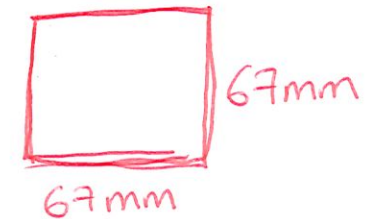

Area = 448.9 cm<sup>2</sup>

Perimeter = 26.8 cm

$$P = L + w + L + w$$

$$= 67 + 67 + 67 + 67$$

$$P = 268\text{mm}$$

(1 mark)

$$A = L \times w$$

$$67 \times 67$$

$$A = 4489\text{mm}^2$$

$$10\text{mm} = 1\text{cm}$$



# DAY 8

## Arithmetic Questions

1  $60 \times 70 =$

$6 \times 7 = 42$

4200

1 mark

2  $3.78 - 0.5 =$

$$\begin{array}{r} 3.78 \\ - 0.50 \\ \hline 3.28 \end{array}$$

3.28

1 mark



3  $20\% \times 340 =$

$x = \text{of}$

$10\% \text{ of } 340 = 34$   
 $20\% \text{ of } 340 = 34 + 34$   
 $= 68$

68

1 mark

4  $6.492 \div 8 =$

$$\begin{array}{r} 0.811 \text{ r}4 \\ 8 \overline{) 6.492} \end{array}$$

$811\text{r}4$

1 mark

5  $12 \div (4 - 2) =$

$4 - 2 = 2$   
 $12 \div 2 = 6$

6

1 mark

## DAY 8 – Reasoning Questions

1.

Toby has  $\frac{3}{4}$  of £160 and Paul has  $\frac{3}{8}$  of £240. How much more money does Toby have?

$$\frac{3}{4} \text{ of } \pounds 160 = \pounds 120 \quad \pounds 120 - \pounds 90 = \pounds 30$$

$$\frac{3}{8} \text{ of } \pounds 240 = \pounds 90$$

£30 (1 mark)

2.

Circle all the improper fractions that are equivalent to 4.

$4 \times 12 = 48$   
 $4 \times 4 = 16$

|                |                 |                |                |               |
|----------------|-----------------|----------------|----------------|---------------|
| $\frac{12}{6}$ | $\frac{48}{12}$ | $\frac{30}{8}$ | $\frac{16}{4}$ | $\frac{4}{9}$ |
|----------------|-----------------|----------------|----------------|---------------|

(1 mark)

3. Draw lines to join the decimal with the equivalent fraction.

|      |                  |
|------|------------------|
| 0.25 | $\frac{3}{4}$    |
| 0.34 | $\frac{1}{5}$    |
| 0.75 | $\frac{7}{100}$  |
| 0.7  | $\frac{40}{100}$ |
| 0.04 | $\frac{7}{10}$   |

$$\frac{3}{4} = \frac{75}{100}$$

(1 mark)

4.

Use the symbol  $< > =$  to make this statement true.

25% of £300 > 15% of £400

$25\% = \frac{1}{4}$  (1 mark)  
 $\frac{1}{4} \text{ of } \pounds 300 = \pounds 75$   
 $10\% \text{ of } \pounds 400 = \pounds 40$   
 $5\% \text{ of } \pounds 400 = \pounds 20$

5.

Bobby and Sue are sharing a cake. Bobby wants to eat 25% of the cake. Sue wants to eat  $\frac{2}{5}$  of the cake. Sue thinks she will be eating the same amount as Bobby. Explain why Sue is wrong.

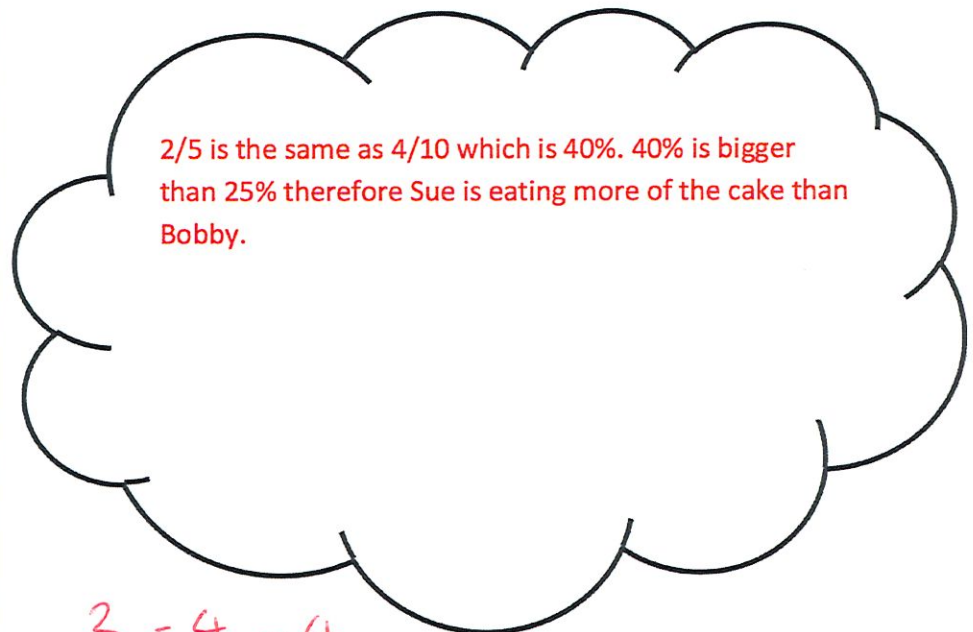

$$\frac{2}{5} = \frac{4}{10} = \frac{40}{100} = 40\%$$

(1 mark)

**Arithmetic Questions**

1  $-13 + 21 =$

8

1 mark

2  $\frac{3}{4} \div 2 =$

$\frac{3}{8}$

1 mark



3  $\underline{\hspace{2cm}} = 578,300 - 600$

577700

1 mark

4  $7.454 \div 16 =$

$465^{r14}$

2

5  $\frac{4}{6} \times \frac{1}{3} =$

$\frac{4}{18}$

1 mark



# DAY 9 – Reasoning Questions

1

Circle all the multiples of 8 listed below:

240 113 98 808 1800

$3 \times 8 = 24$

$8 \times 100 = 800$  (1 mark)

$$\begin{array}{r} 0225 \\ 8 \overline{) 1800} \\ \underline{8} \phantom{00} \\ 0 \phantom{00} \\ \underline{0} \phantom{00} \\ 000 \\ \underline{000} \\ 000 \\ \underline{000} \\ 000 \end{array}$$

2

Write all the common multiples of 5 and 9 that are less than 100.

45, 90

5, 10, 15, 20, 25, 30, 35, 40, 45, 50, 55, 60, 65, 70, 75, 80, 85, 90, 95, 100 (1 mark)  
9, 18, 27, 36, 45, 54, 63, 72, 81, 90, 99

3

Tina is thinking of 2 square numbers. The difference between them is 11. When she adds them together the total is 61. What two square numbers is Tina thinking of?

$\square$  1, 4, 9, 16, 25, 36, 49, 64, 81, 100 25 and 36 (1 mark)

$36 - 25 = 11$

$36 + 25 = 61$

4

Complete the prime numbers:

3  7 9   17 (1 mark)

5

What is the lowest common multiple of 9 and 12?

9 12  
18 24  
27 36  
36 (1 mark)

6. Write the number 6 less than 1 million.

999994 (1 mark)

**Arithmetic Questions**

1  $13 \times 3 \frac{1}{12} = 40 \frac{1}{12}$

$3 \times 13 = 39$

$\frac{1}{12} \times 13 = \frac{13}{12} = 1 \frac{1}{12}$

$40 \frac{1}{12}$

1 mark

2  $12 \times 0.7 = 8.4$

$12 \times 7 = 84$

$8.4$

1 mark



3  $35\% \text{ of } 260 = 91$

$10\% \text{ of } 260 = 26$

$5\% \text{ of } 260 = 13$

$30\% \text{ of } 260 = 26 \times 3 = 78$

$78 + 13 = 91$

$91$

1 mark

4  $212 - 9 = 203$

$212 - 10 = 202$

$203$

1 mark

5  $2 \times 3 \times 2 = 1,200 \div \underline{100}$

$2 \times 3 = 6$

$6 \times 2 = 12$

$1200 \div \underline{\hspace{2cm}} = 12$

$100$

1 mark

## DAY 10 – Reasoning Questions

1.

Complete the pattern to make the pattern symmetrical.

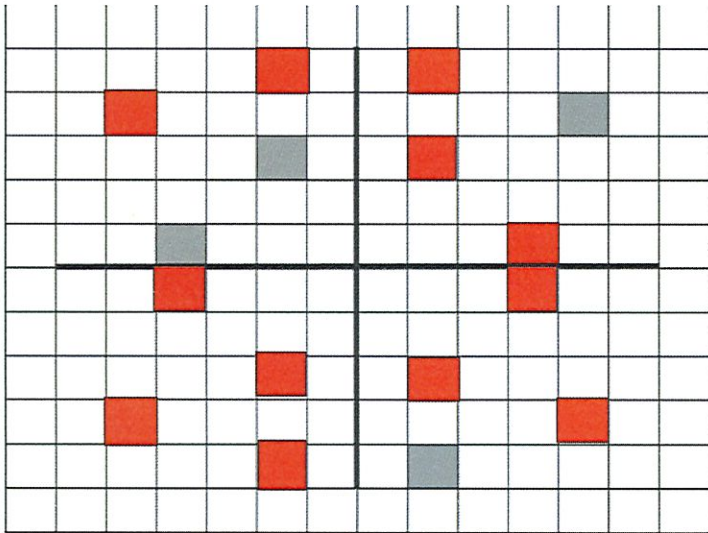

(1 mark)

2. Write these numbers in descending order.

176490    167940    174609    169470

*down*

10740

*only 5 digits*

|        |        |        |        |       |
|--------|--------|--------|--------|-------|
| 176490 | 174609 | 169470 | 167940 | 10740 |
|--------|--------|--------|--------|-------|

largest

smallest (1 mark)

3. Lloyd works for 165 days of the year. How long is this in weeks and days?

$$7 \overline{) 165} \begin{array}{r} 23 \\ \underline{14} \phantom{0} \\ 25 \end{array} \begin{array}{l} r4 \end{array}$$

23 weeks and 4 days (1 mark)

4. The table shows the temperature in different cities.

| City        | Temperature °C |
|-------------|----------------|
| London      | 7              |
| Birmingham  | -3             |
| Edinburgh   | -9             |
| Leeds       | 0              |
| Cardiff     | -4             |
| Brighton    | 8              |
| Southampton | 11             |

What is the difference in temperature between London and Cardiff?

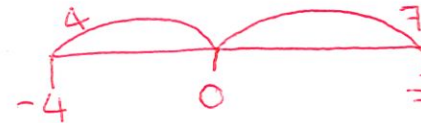

11°C (1 mark)

The temperature in Birmingham increases by 14°C. What is the temperature in Birmingham now?

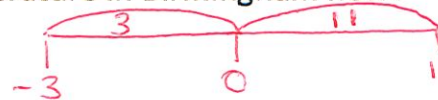

11°C (1 mark)

5. Polly has 5 bags of sweets. In each bag there are 21 sweets. She wants to share them equally between 6 people. How many sweets does each person get?

$$5 \times 21 = 105 \text{ sweets}$$

$$6 \overline{) 105} \begin{array}{r} 17 \\ \underline{12} \phantom{0} \\ 5 \end{array} \begin{array}{l} r3 \end{array}$$

17 (1 mark)